

The Utility of Fission-Fusion Hybrid Nuclear Power in a Mars Mission

John Brandenburg



The Following Talk was First given at the STAIF II Meeting in Albuquerque which welcomes all new ideas regarding space and energy

Agenda

- Motivation
- Breakthrough: compact and safe Fission-Fusion Hybrid Nuclear energy for Earth and Space
- Application for Mars Base Power
- Summary

Motivation: Mars Site Power

- Mars dust storms can cutoff sunlight on Mars for Months

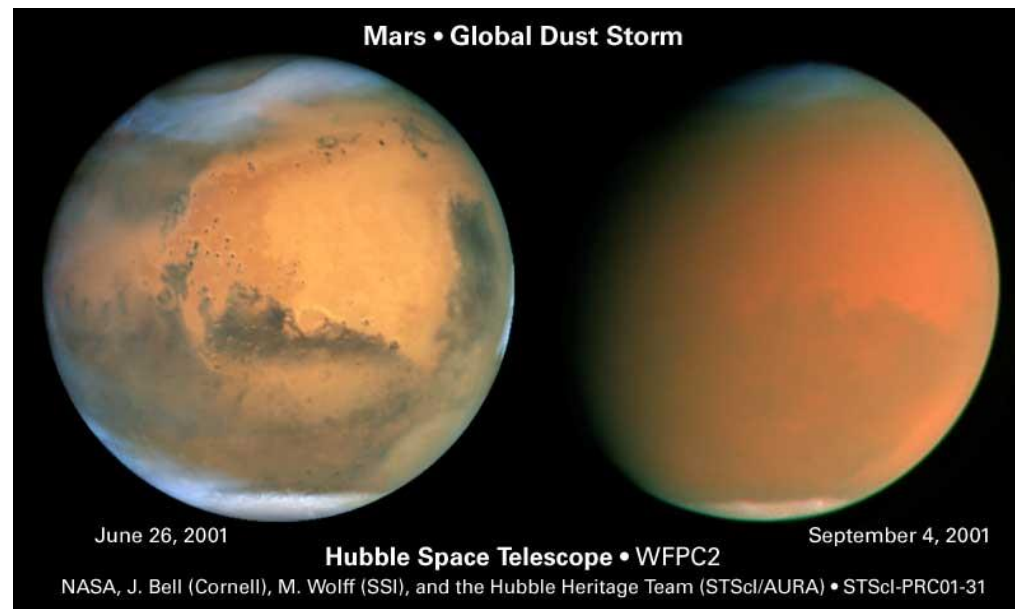

- Astronauts must have nuclear power for Mars surface base

Additional Terrestrial Motivation: The Jihad

- The Jihad against the United States is funded by Oil



- To win *War on Terror* we must win the *War on Oil*

Energy Distribution History

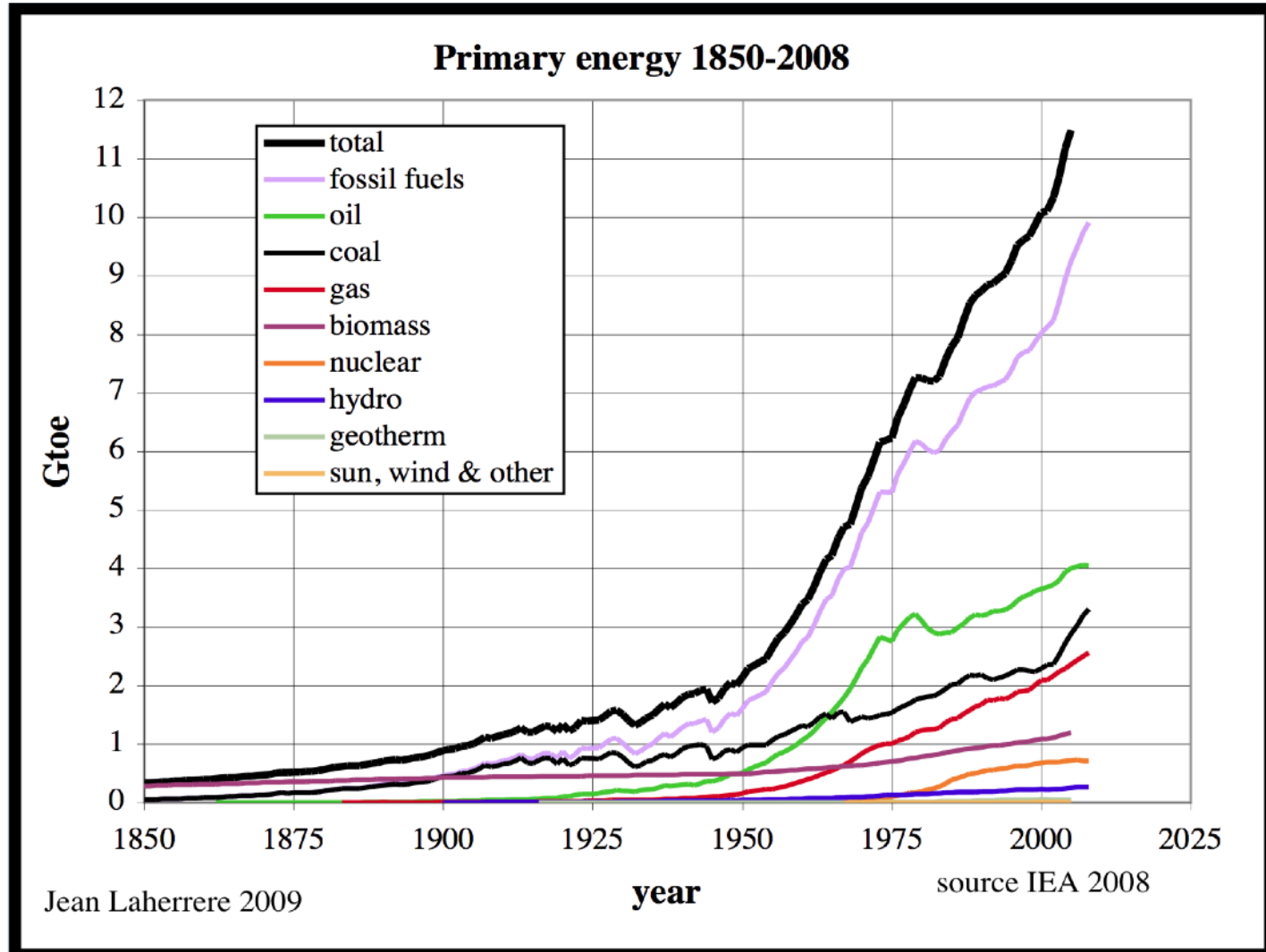

Global CO₂ and Oxygen

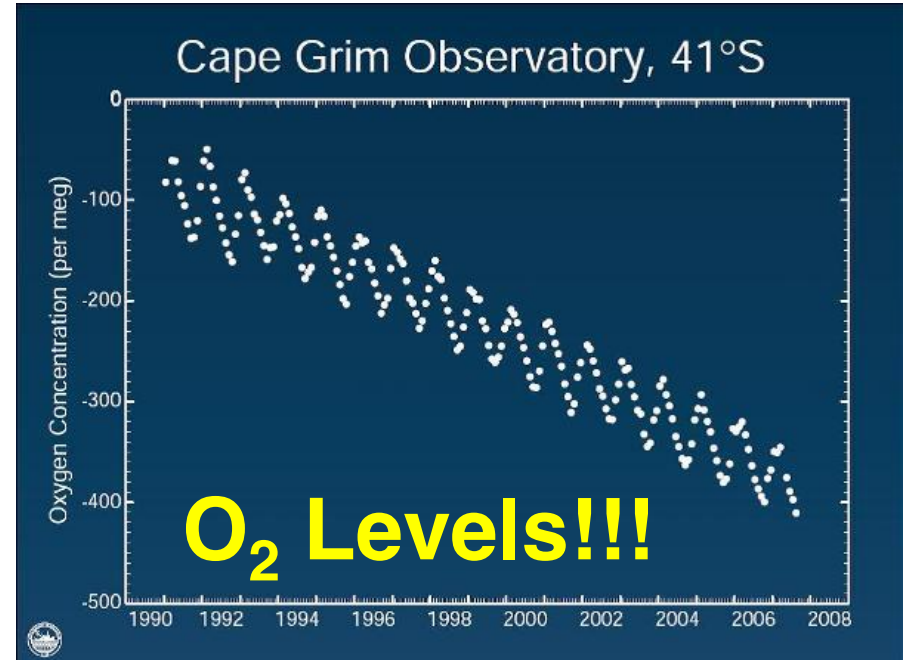
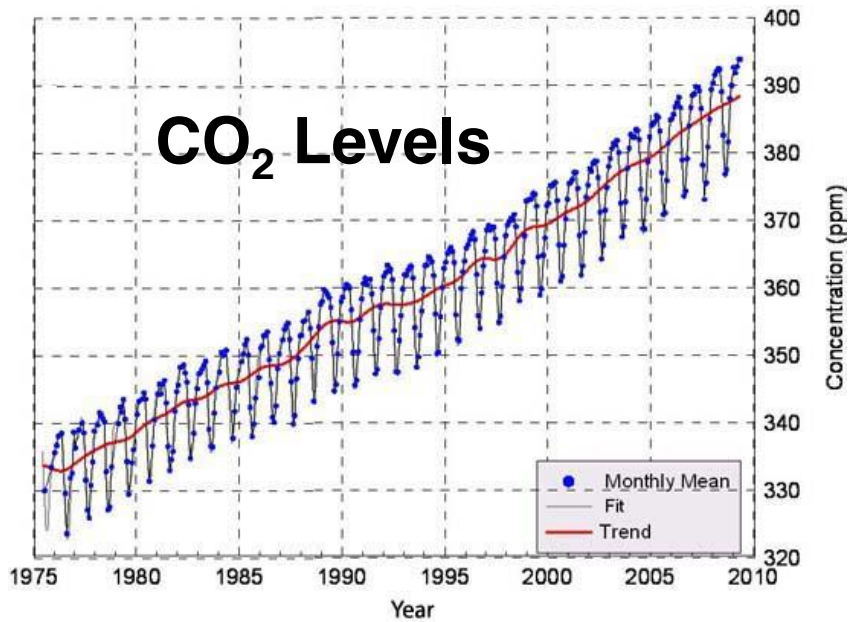

RS8-14-2383



Houston , We have a Problem...

Solution

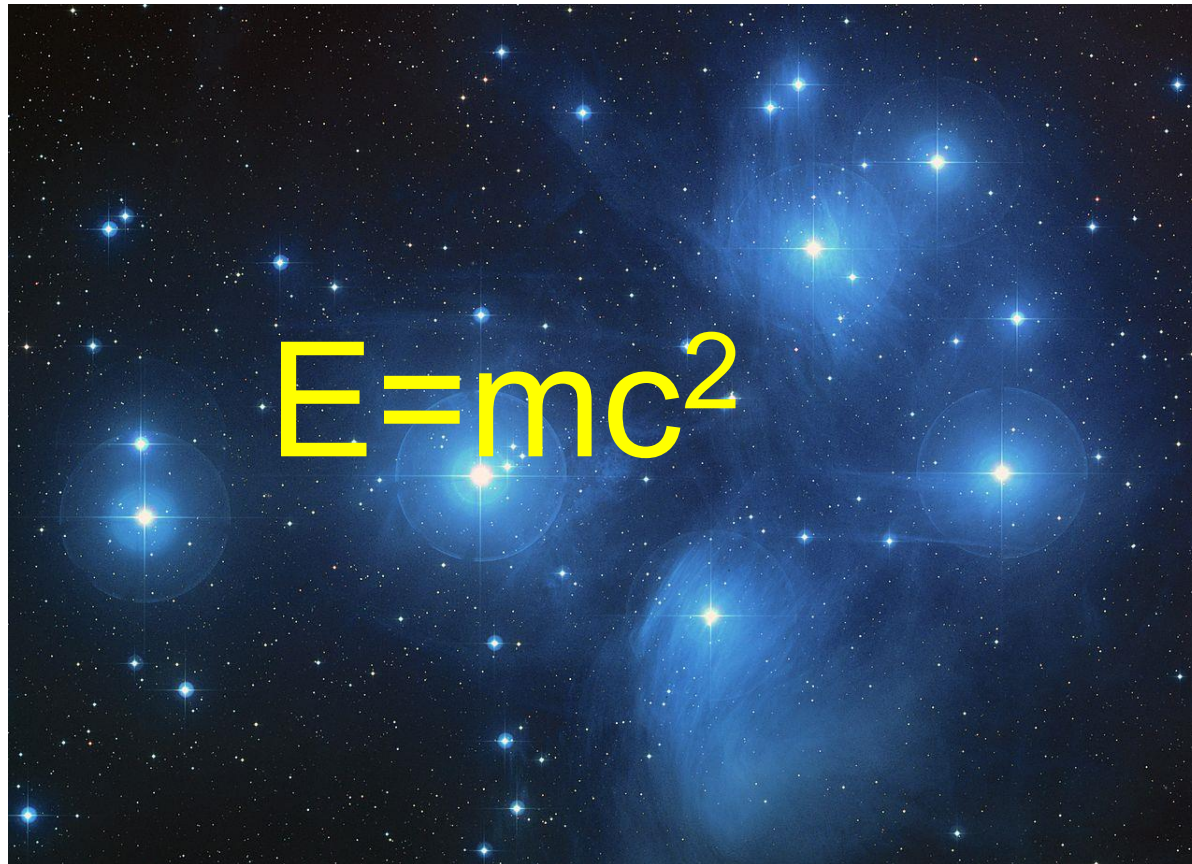

The Unseen Breakthrough: 1994

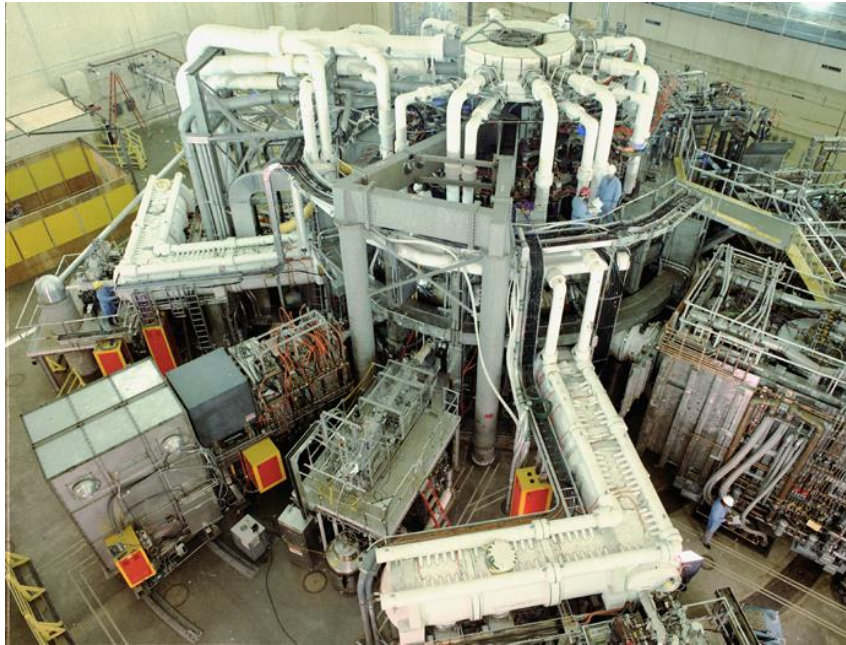

TFTR- Princeton N.J.

TFTR produces 10.7MW Fusion power - 27%
of heating power ($Q=.27$)

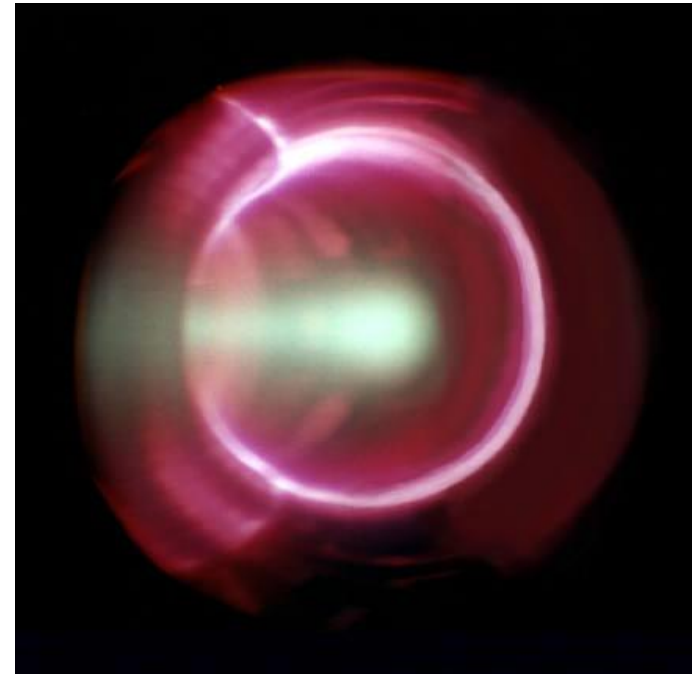

TFTR plasma

Breakthrough

- United States Fusion Program exceeded “Hybrid Breakeven” in 1995 at TFTR (Tokamak Fusion Test Reactor) which achieved 27% scientific breakeven ($Q=.27$) burning DT (Deuterium and Tritium)
- Fission gives 10x energy yield per neutron as Fusion
 - » Each Fusion reaction produces 17.5 MeV and a fast neutron
 - » Each neutron can produce a 180 MeV Fission reaction
- ***If TFTR had been fitted with a Uranium blanket – it would have been $Q\sim 10$***

Fusion Reactions

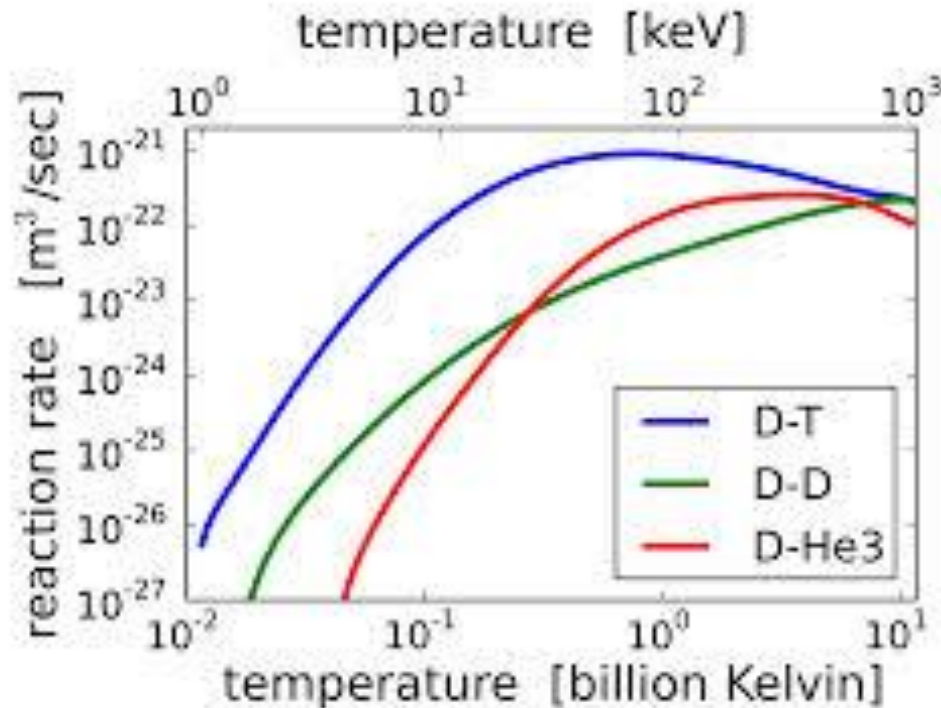

- D-T Neutron rich Fusion is easier than “a-neutronic fusion’

Fission vs Fusion Energies

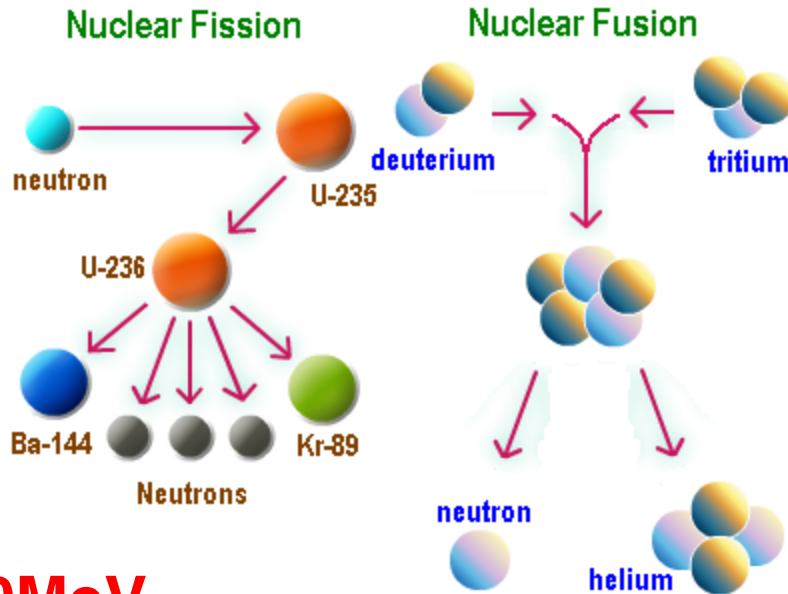

Fusion 18MeV
(14 MeV neutron)

Fission 250MeV

- Fusion makes high energy neutrons Fission makes 10 x more energy

Why was The Breakthrough not Previously Seen?

Simple : ***“In the Box”*** Thinking

- The Breakthrough was not seen because both Fission and Fusion “camps” were focused only on “Pure Fusion” or “Pure Fission” (Fast Breeders).
- Hybrid power: Fusion for generating neutrons- Fission for creating power.

Fission Fusion Hybrid Nuclear Reactor

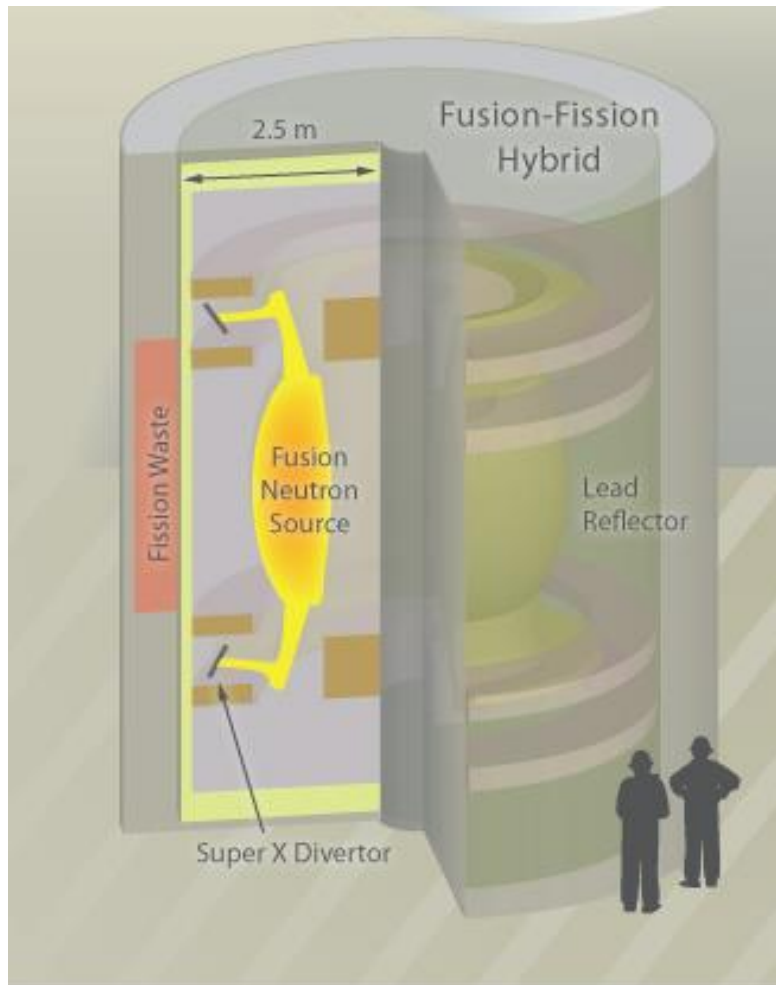

- Hybrid Reactor consists of Fusion core and Sub-Critical Fission Blanket that surrounds the fusion source.
- Fusion Core acts as a neutron Source to make fission blanket critical
- Fission Blanket acts as Power Multiplier.
- Result : Electronically controlled Fission Reactor.

Fusion Neutrons Can Transmute Nuclear Waste

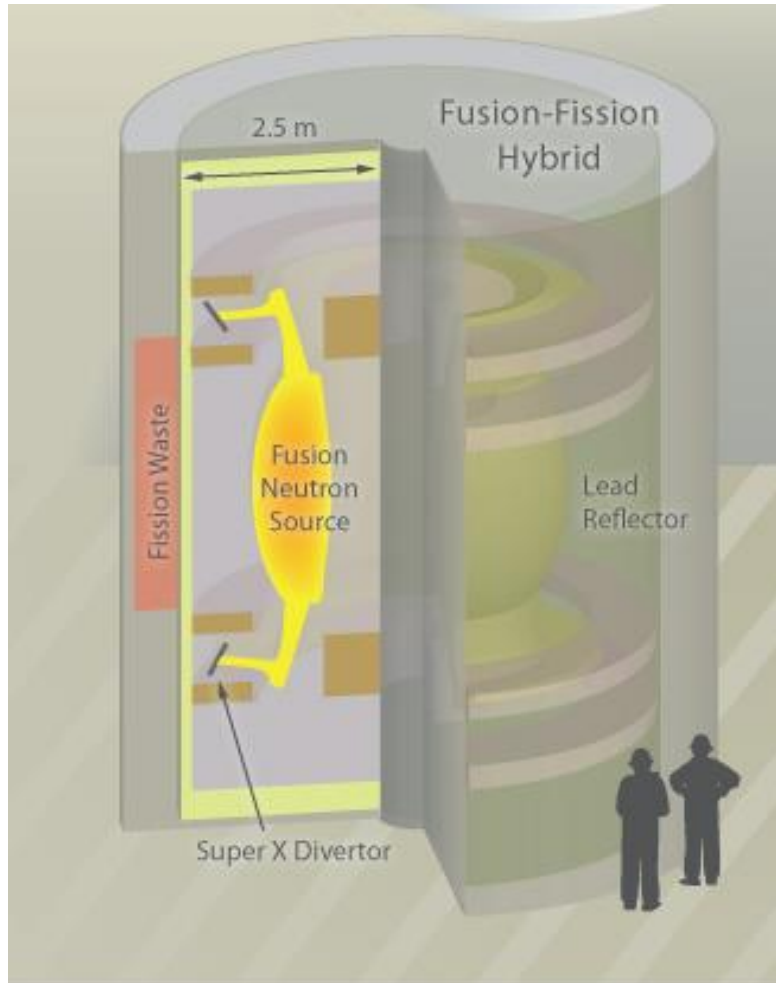

- Fusion core Neutrons can “burn up” High Level Nuclear waste and render it “50 year safe”

Pressurized-Water Reactor Technology can be used

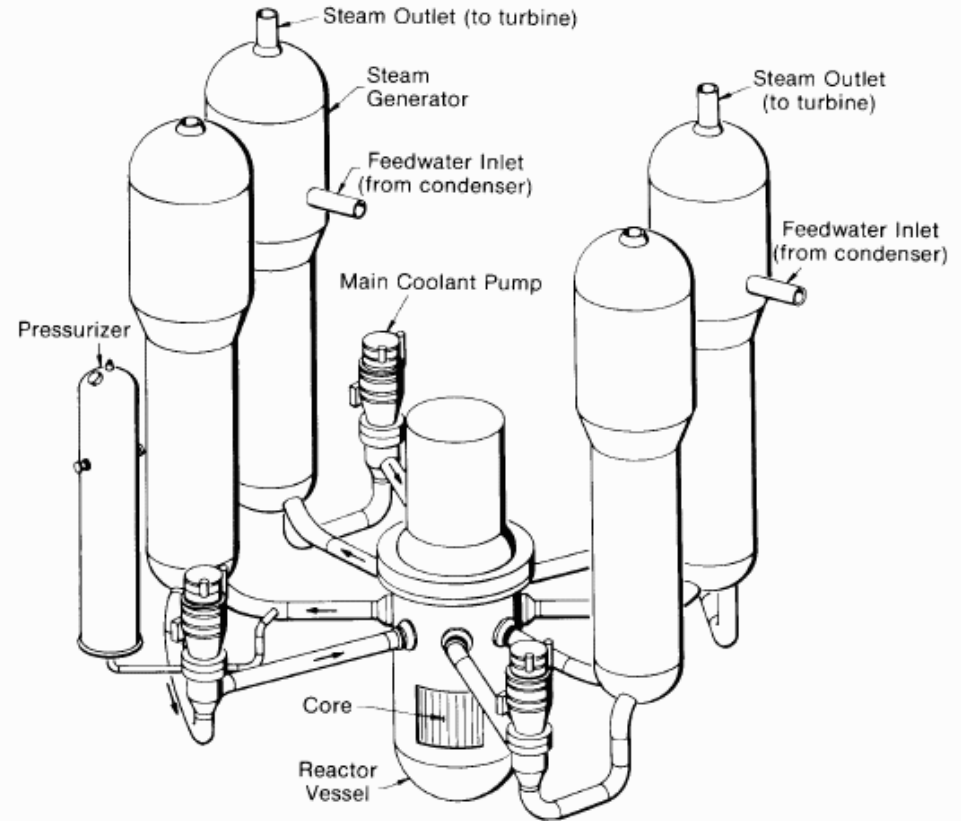
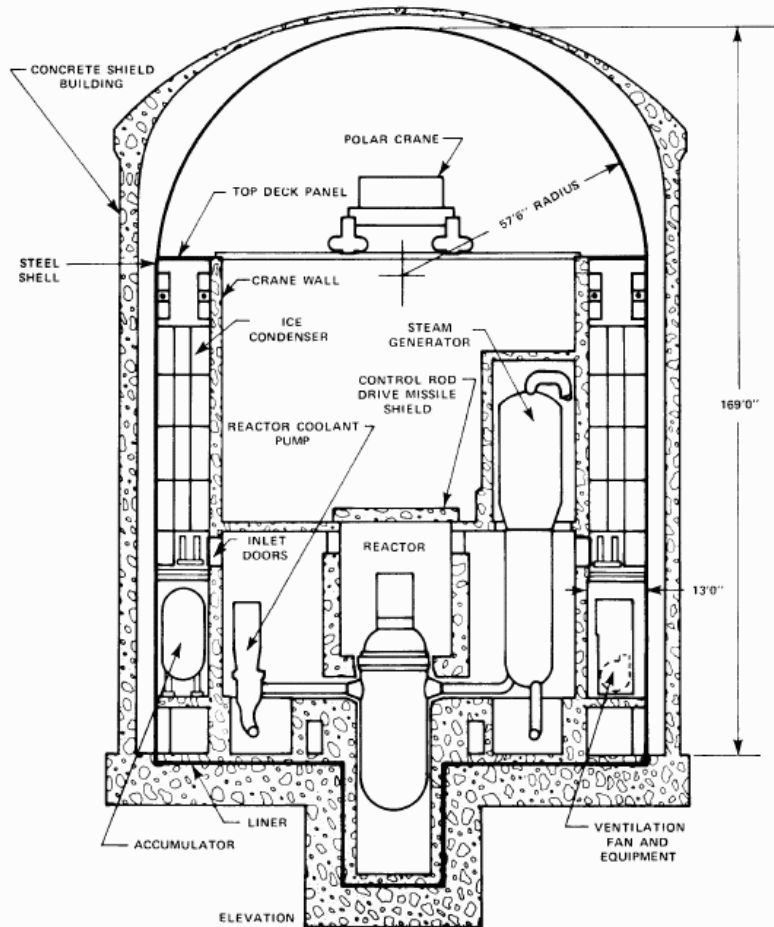

Advantages of Hybrid Nuclear Power

- Fusion elements are much easier to design than pure fusion and technology was demonstrated using Tokamaks.
- Hybrid Nuclear plant can operate partially on high level rad-waste or Thorium rendering it safer than current fission systems.
- Hybrid allows safe breeding of Fission Fuels.

*The Energy Crisis is Solved**

** In Theory ...*

Application To Mars

- Fusion Neutron Source powered by Solar Power can provide neutrons in-flight to Mars
- Thorium Fission Blanket can be “Launched Inert” and made critical on the way to Mars

Mars Site Power Hybrid : At Launch

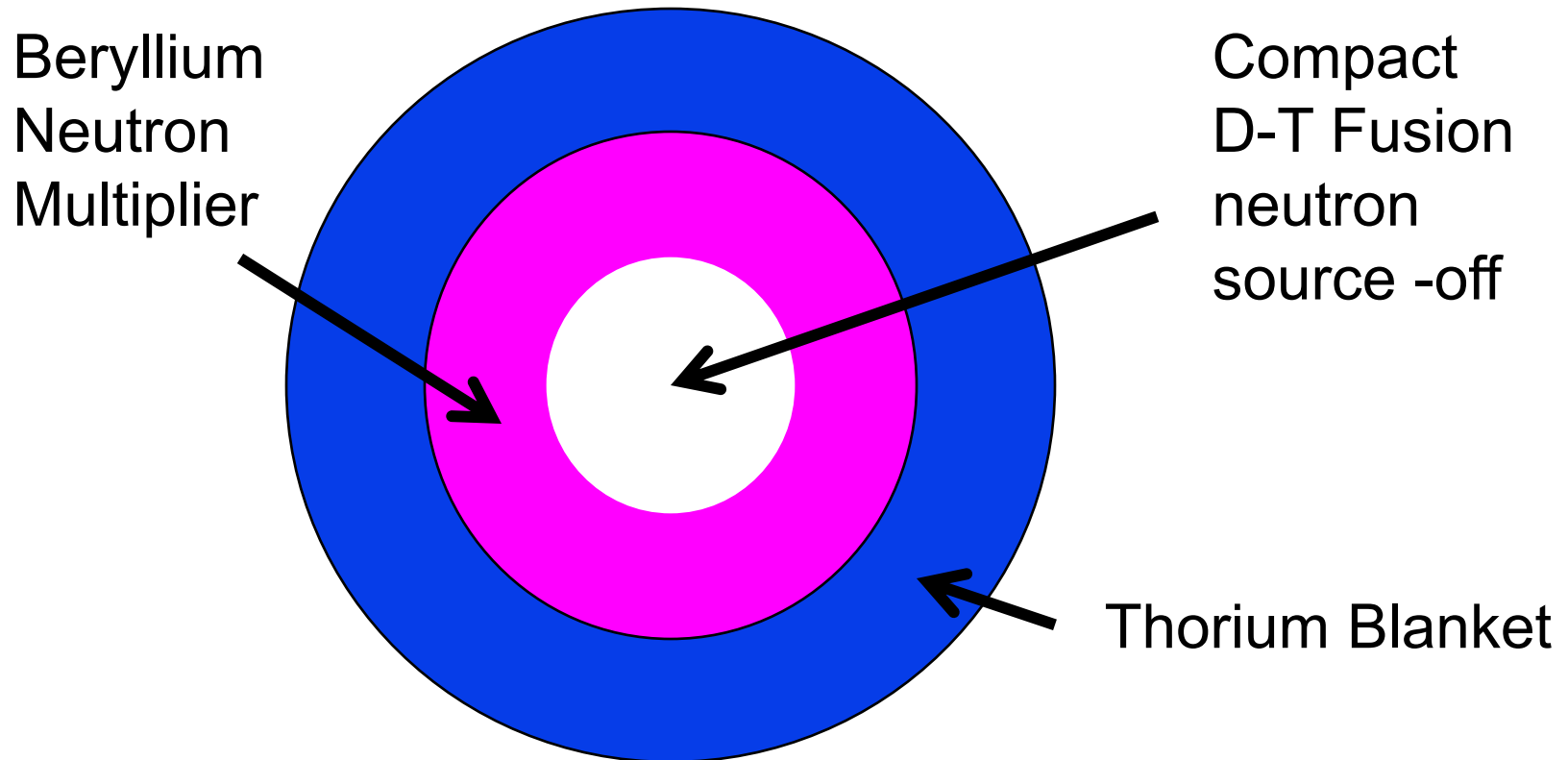

- Thorium is inert

Mars Site Power Hybrid : At Mars

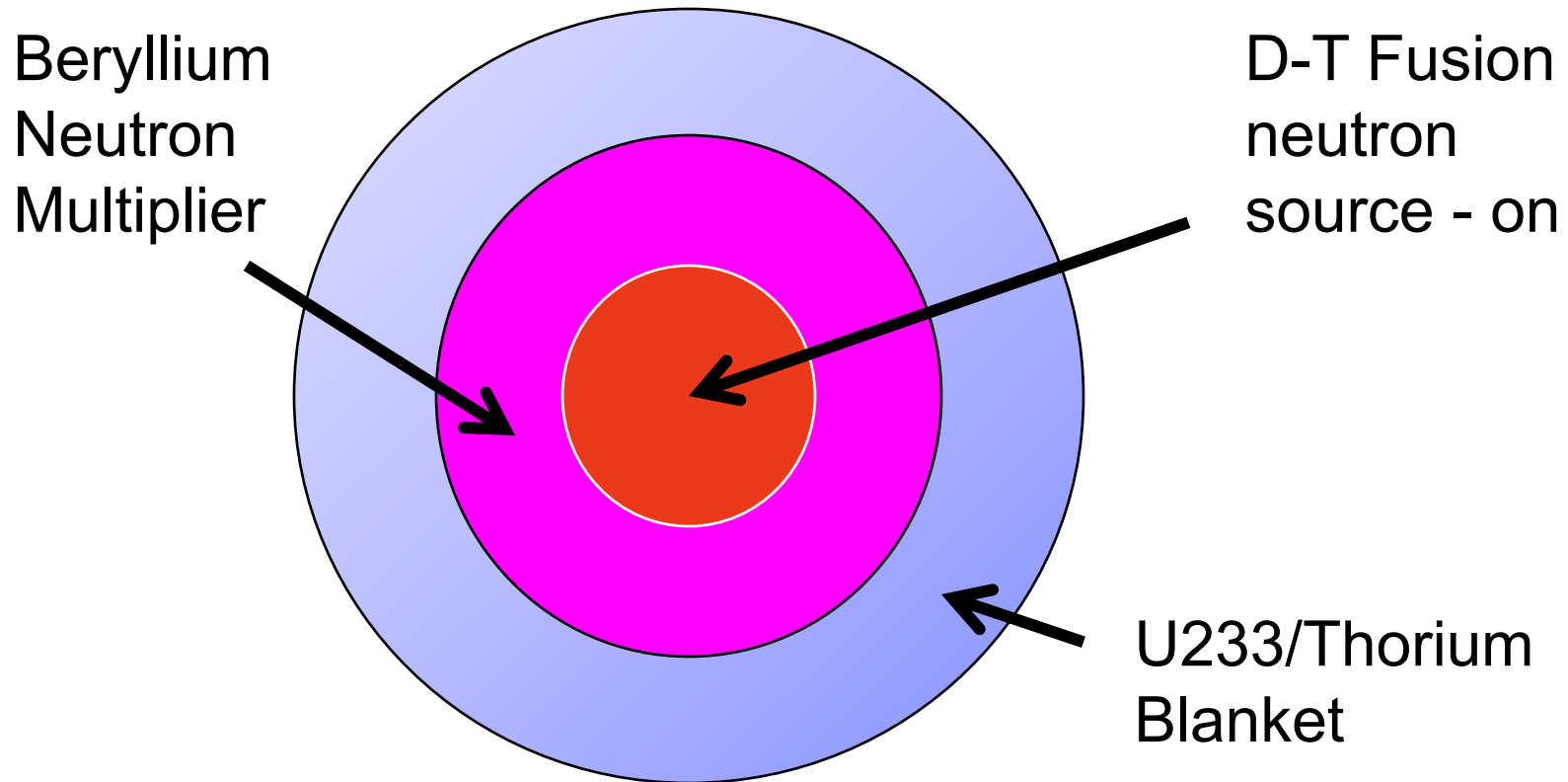

- Thorium is converted to U233 on Hohlmman transfer to Mars

Power on Mars - *Dust or no Dust*



Two Approaches for Stable Fusion Core

Fusion Core 1. RTEX (Rifled Toroidal vorTEX) magnetic confinement

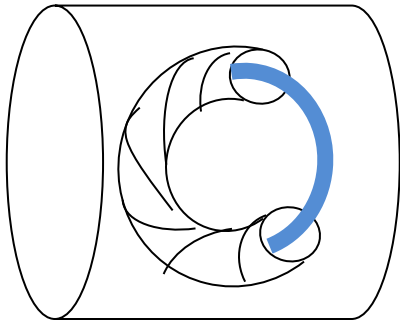

Fusion Core 2. IEC with Microwave Augmentation

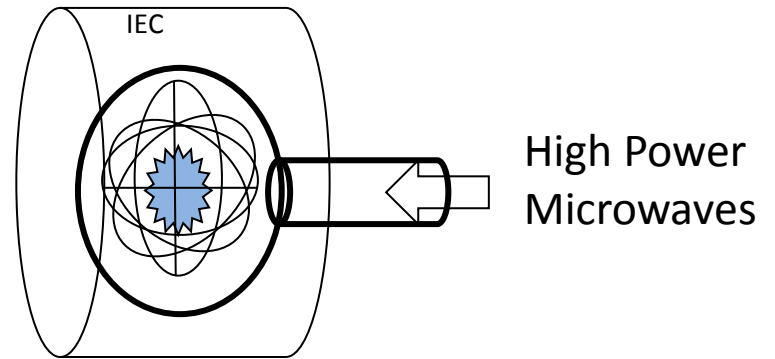

Vortex Stabilized magnetic configurations

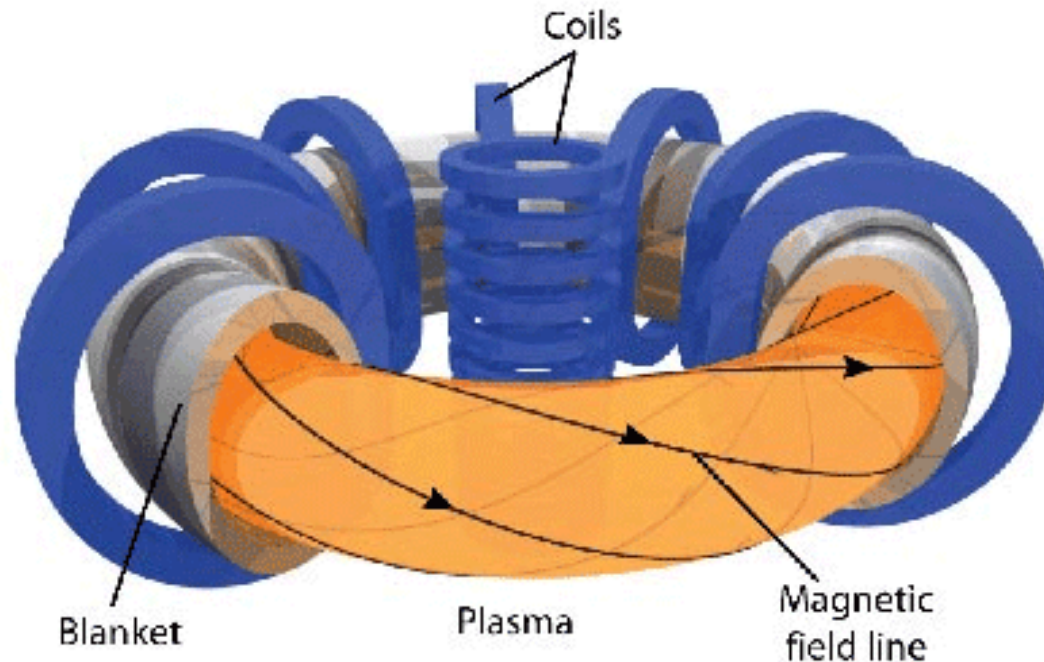

The Toroidal Vortex Magnetic field in a Tokamak

- *demonstrated to be stable.*
- **Critical magnetic field is required to prevent burn through...**

Stable Torsatron Plasma



Simple Torsatron Experiment

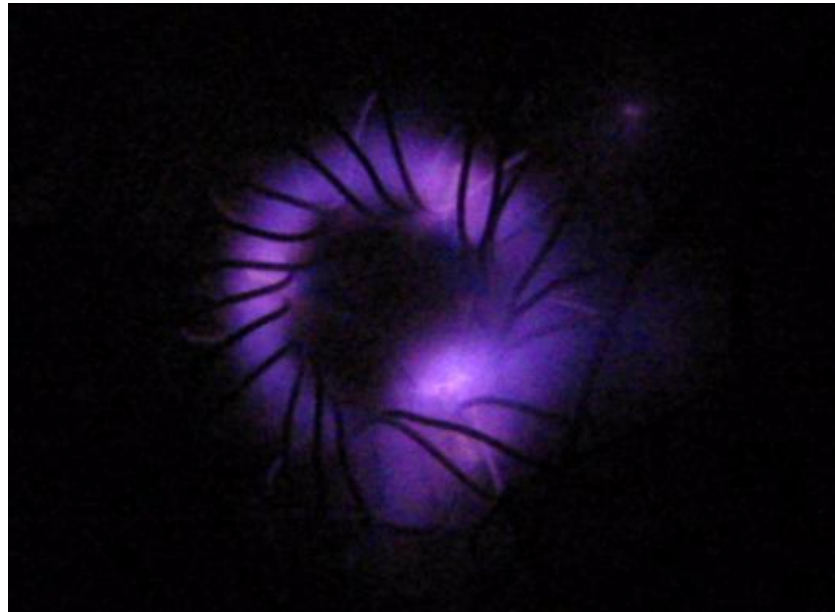

The small Torsatron coil energized with pulsed current confines plasma in a vacuum tank.

IEC –MAX (Microwave Augmentation eXperiment)



Combine proven IEC fusion with Pulsed Radar Sources for augmented confinement



Microwave “Pondermotive” Force on Plasma

$$\nabla \cdot (\rho_e \vec{v}_e \vec{v}_e) + \nabla P_e - en_e E = \nabla \cdot \left(\frac{e^2 n_e}{m_e \omega^2} \vec{E}_m \vec{E}_m \right) + \nabla P_e - en_e E = 0$$

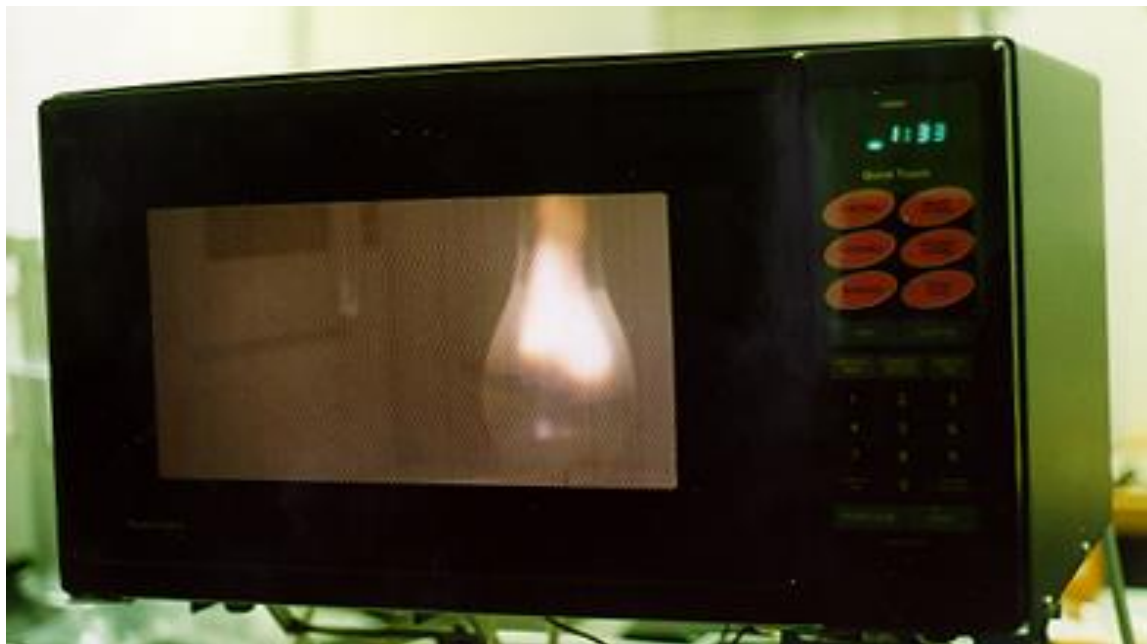

Microwaves can put pressure on plasmas

Virial Theorem – Force Balance

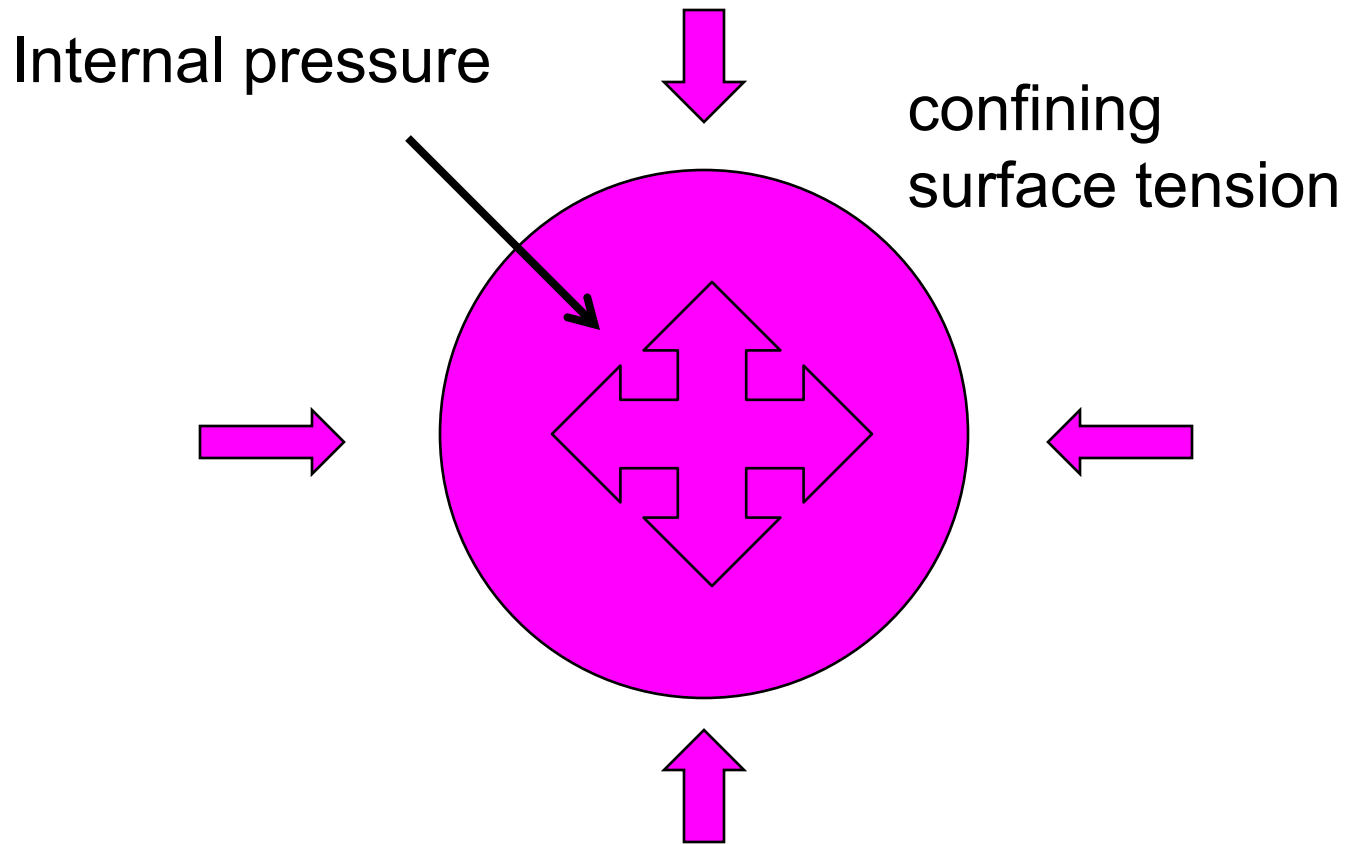

Virial Theorem cont.

electrostatic
force

EM wave force

$$\varepsilon_o (E_c^2 + \frac{\omega_p^2}{2\omega^2} E_m^2) = \langle \rho_i v^2 + 3P_e + \frac{1}{2} \varepsilon_o E^2 \rangle$$

surface term

average internal
pressure

MAX (Microwave Augmentation eXperiment)



Figure 1. The IEC plasma before microwaves.

IEC only



Figure 2. The IEC plasma during microwave irradiation. Note the plasma shrinkage relative to the grid structure as seen Figure 1.

IEC With Microwave
Augmentation ~ 1kW
2.45GHz

Summary

Hybrid Fusion- Fission offered near term safe-clean nuclear power for earth and space.

Energy crisis now has a technical fix

Limitless safe-clean energy

Fusion neutron source powered by solar power can transmute inert thorium blanket to fissionable U-233 en-route to Mars or on Mars surface

Mars nuclear site power can be launched inert and be activated en-route or on Mars

Goal: Hybrid Nuclear Powered Spacecraft

